

Fixture Type:



S6C-3055Z-110-150  
pictured

The Shakespeare CDM zoom ellipsoidals are truly a state of the art luminaire in style, versatility of functions and efficiency. Configured with a 39W, 70W or 150W ballast, these lighting fixtures with their respective Ceramic Discharge Metal Halide lamps will direct bright, sharp or soft-edged illumination to their subject.

Each unit has two accessory slots and replaceable accessory holders with two generous channels. The slot nearest to the lamp is specifically sized to accept pattern holders for metal gobos with 2 5/8 inch image diameters ("B" size). The second slot, which has a cover to eliminate light leak when not in use, will accept a glass pattern holder, or a drop-in iris or gobo or dual gobo rotators. The dual channel accessory holder with self-closing and latching retainer accepts 7 1/2 inch color frames, glass color frames, donuts, snoots or color changers and combination of accessories as required.

These low wattage, long lamp life units produce a cool light with a high color rendering index that will not seriously impact ambient temperatures. With the obvious advantage of variable focus for beam diameters and pin-pointing abilities, the units are ideally suited for projecting company logos with varying size requirements, spotlighting and enhancing corporate signs/logos or lighting trade show booths, especially when different size products, furnishings, or areas need to be illuminated.

Specifications subject to change without notice

39/70/150 WATT  
SHAKESPEARE ZOOM CDM

Features

- 12,000 hour CDM lamp with high color rendering index
- Compact, rugged die-cast aluminum construction
- Lockable, 180° indexed rotation of shutter assembly and lens barrel, optional 360° rotation
- Color Coded lens barrel identification system
- Tempered crown glass lenses have anti-reflective coating
- Zoom focus lens carriers use Teflon glide bearings on stainless steel guide rails
- Tool free operating lamp centering knob and peak to flat field adjustment knob
- Replaceable two-slot accessory holder provided with self-closing and self-locking accessory retaining latch
- Accessory slot provided with locking cover that will accept rotating gobo accessories, glass pattern holder and drop-in-iris
- Removable lens access panel
- Tool free removable heavy gauge stainless steel shutters mounted in separate planes equipped with oversized insulated handles, and spring pressured shutter assembly
- Dual positioning yoke supplied with dual positive locking dogs and tilt angle markings
- Protective insulated rear mounted ring handle serves as a cord wrap, stand, and focusing aid
- G9.5 medium two-pin lampholder provided with heat shield that accepts a wide variety of non-proprietary lamps
- Uses standard 7 1/2" accessories
- Three 36" Teflon lead wires
- Up to 25' of Hi-Temp rubber cable optional
- Color frame and safety cable included
- U.L. and c.U.L. listed with their respective lamps
- Made in the USA

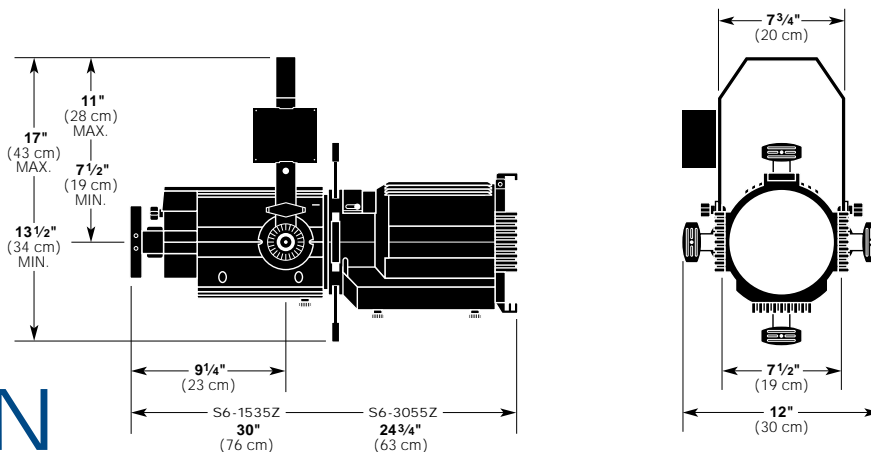

# 39/70/150 WATT SHAKESPEARE ZOOM CDM

## Specifications

**Housing:** Die-cast aluminum.

**Materials:** Construction employs corrosion resistant materials and hardware.

**Yoke:** Rigid flat steel with positive eccentric disc locking with indexing for easy repositioning of tilt angle.

**Reflector:** Alzak aluminum, ellipsoidal design

**Lenses:** Crown Glass (white plate) with anti-reflective coated surfaces.

**Lens Barrel:** Die-cast aluminum

**Lamp/Socket:** 39W, 70W or 150W UV Block G12 Ceramic Metal Halide lamp. 5kV pulse rated socket.

**Ratings:** 120 volt AC operation; 50/60Hz .38 amps with 39W lamp and 39W ballast; .58 amps with 70W lamp and 70W ballast; 1.25 amps with 150W lamp and 150W ballast. 240 and 277 VAC units are available.

**Ballast:** Aromat Corp. 39W, 70W and 150W NAIS DCP Electronic Ballasts. Unit carries a full 5 year warranty tested and approved by Aromat.

**Cable:** 4 feet of insulated 3 conductor cable with molded U-ground male edison plug.

**Lamp Alignment:** Fully adjustable in 3 axis with the use of two heat resistant concentric knobs.

**Focusing:** Lens barrel travels on nylon glides and then friction locks using a heat-resistant Knurled knob.

**Accessories:** Front end holders accept 7 1/2 inch x 7 1/2 inch accessories.

**Finish:** Black epoxy sandtex, electrostatic application.

**Weight:** Approx; 23 lbs. (10.4 kg.) for S6C-1535Z.  
Approx; 21 lbs. (9.5 kg.) for S6C-3055Z.

## ORDERING INFORMATION:

Model	Color	Lens	Voltage	Wattage
<b>S6C</b>	<b>Black</b>	-	-	-
	(W)hite	(1535)Zoom	110	39
	(S)ilver	(3055)Zoom	240	70
	(X)custom		277	150

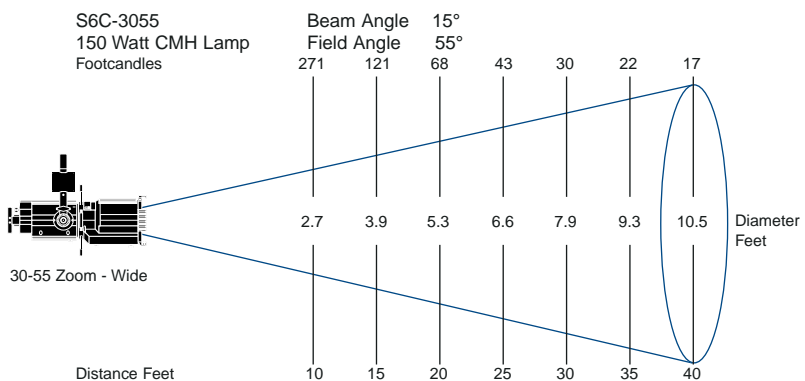
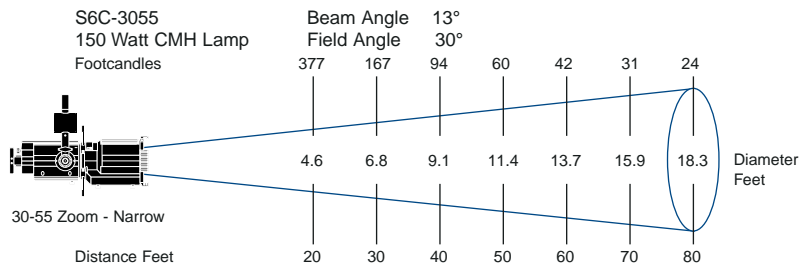
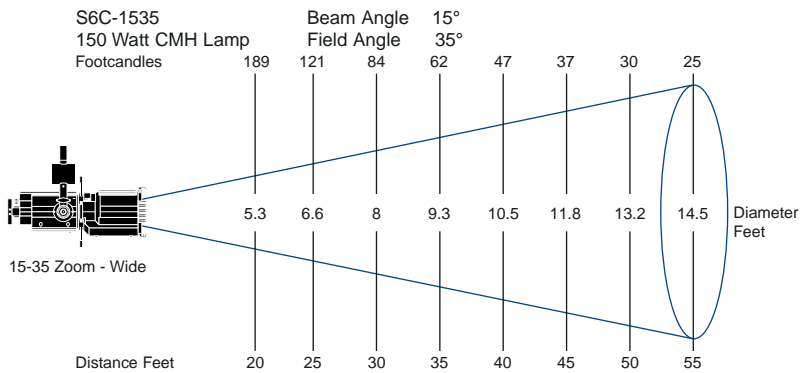
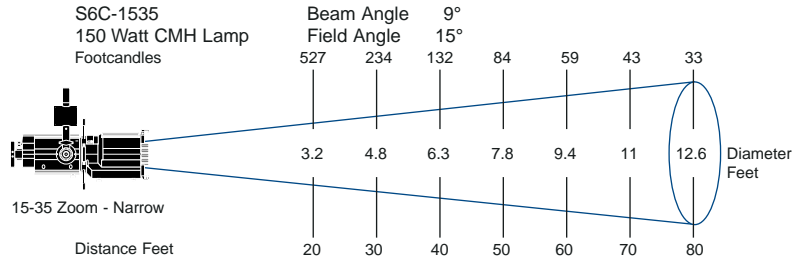

Conversion Factors	
39 Watt Lamp = f.c. x .24	
70 Watt Lamp = f.c. x .48	
Lux = f.c. x .0929	

ACCESSORIES Supplied with Luminaire	
6-CF	Color Frame, 7 1/2" x 7 1/2"
SC	Safety Cable with Spring Clip

ADDITIONAL ACCESSORIES	
510	Malleable Iron Pipe Clamp
360-PH	Pattern Holder with Channels, 2 3/4" diameter opening, 3 3/8" wide
1KL6-PH	Pattern Holder with Slots, 2 3/4" diameter opening, 3 3/8" wide
S6-GPH	Pattern Holder for Glass Patterns
6-SN	Snoot
404-6	Motorized Color Wheel
6-DN	Donut, 7 1/2" x 7 1/2" w/3" diameter opening
SDii	Drop-in iris
90-35CDMT6/830	39 Watt CDM Lamp 3000K-12,000 Hr.
90-70CDMT6/830	70 Watt CDM Lamp 3000K-12,000 Hr.
90-70CDMT6/942	70 Watt CDM Lamp 4000K-12,000 Hr.
90-150CDMT6/830	150 Watt CDM Lamp 3000K-12,000 Hr.
90-150CDMT6/942	150 Watt CDM Lamp 4000K-6,000 Hr.
90-150CDMSA/942	150 Watt CDM Lamp 4200K-5,000 Hr. Short Arc

## LAMP DATA

Lamp Type	Watts	Efficiency	Color Temp (°K)	Rated Life (Hours)	Rated Lumens	Color Rendering Index	Burn Position
CDM 35/T6/830	39	>87 LPW	3000	12,000	3,400	81	Any
CDM 70/T6/830	70	>92 LPW	3000	12,000	6,600	82	Any
CDM 70/T6/942	70	>92 LPW	4000	12,000	6,600	92	Any
CDM 150/T6/830	150	>93 LPW	3000	12,000	14,000	85	Any
CDM 150/T6/942	150	>85 LPW	4000	6,000	12,700	95	Any
CDM SA150/T6/942	150	>86 LPW	4200	5,000	12,900	96	Any